

- In addition to routine checks for each use, PPE should regularly undergo a detailed inspection by a competent person. Petzl recommends an inspection every 12 months and after any exceptional event in the life of the product.
 - PPE inspection should be conducted with the manufacturer's Instructions for Use.
- Download the Instructions at PETZL.COM

PULLEYS



1. Known product history

Any PPE showing unexpected degradation should be quarantined, pending a detailed inspection.

The user should:

- Provide precise information on the usage conditions.
- Report any exceptional event regarding his/her PPE.

(Examples: fall or fall arrest, use or storage at extreme temperatures, modification outside manufacturer's facilities...)

2. Preliminary observations

Verify the presence and legibility of the serial number and the CE mark.

Note: the serial number code on our products is evolving. Two types of code will coexist. See below for details on each serial number code.

Code A:

00 000 AA 0000

Year of manufacture
Day of manufacture
Name of Inspector
Incrementation

Code B:

00 A 0000000 000

Year of manufacture
Month of manufacture
Batch number
Incrementation

Verify that the product lifetime has not been exceeded.

Compare with a new product to verify there are no modifications or missing parts.

3. Checking the condition of the side plates

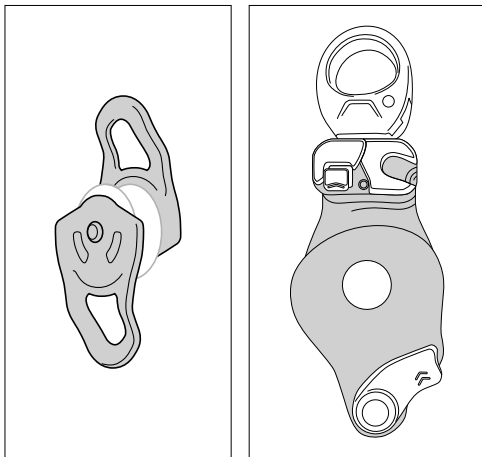

- Check the condition of the side plates (marks, deformation, cracks, wear, corrosion).

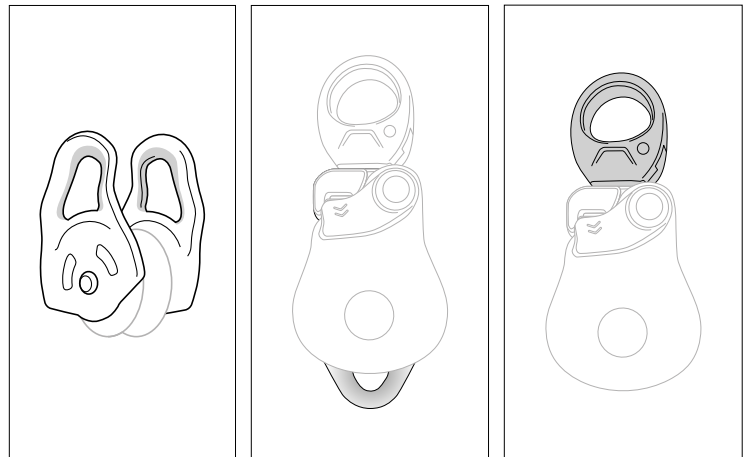

- Check the condition of the attachment holes (marks, deformation, cracks, wear, corrosion...).

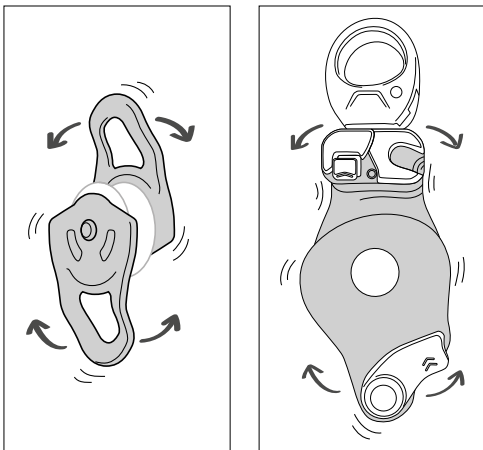

- For pulleys with moving side plates, verify that the side plates rotate properly.

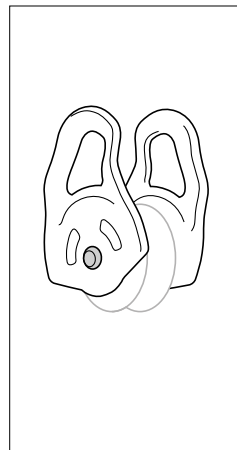

- Check the condition of the rivets (marks, deformation, cracks, corrosion, absence of play...).

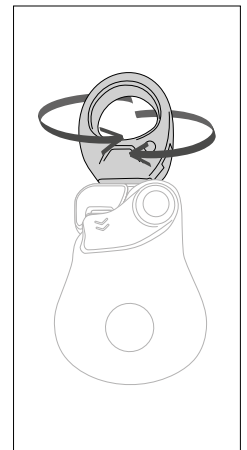

- Check the condition (marks, deformation, cracks, wear, corrosion) and the rotation of the swivel in both directions.

4. Checking the condition of the sheave(s)

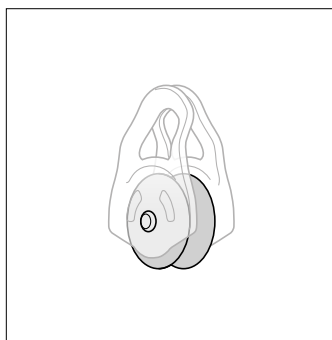

- Check the condition of the sheave (marks, deformation, cracks, wear, corrosion, absence of foreign bodies...).

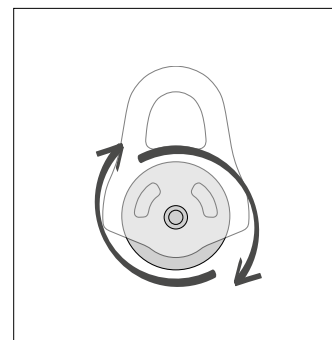

- Verify that the sheave turns freely in both directions.

Sheave on ratcheting wheel, SPIN L1D

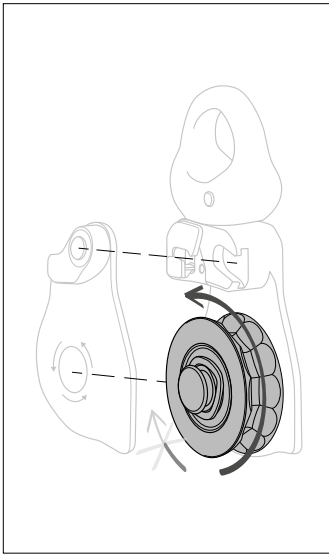

- Check the condition of the ratcheting wheel (marks, deformation, cracks, wear, corrosion...). Verify that the sheave turns in the desired direction and blocks in the other direction.

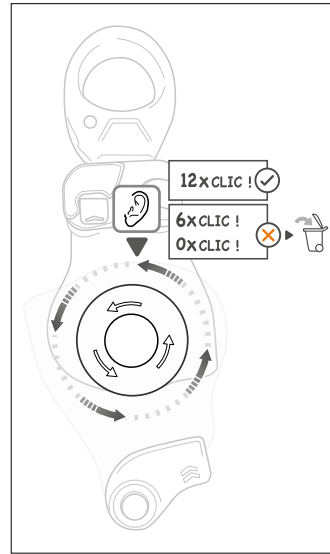

- Count the number of clicks of the ratcheting wheel. You must hear 12 clicks during one complete rotation.

5. Checking the side plates' opening and locking systems

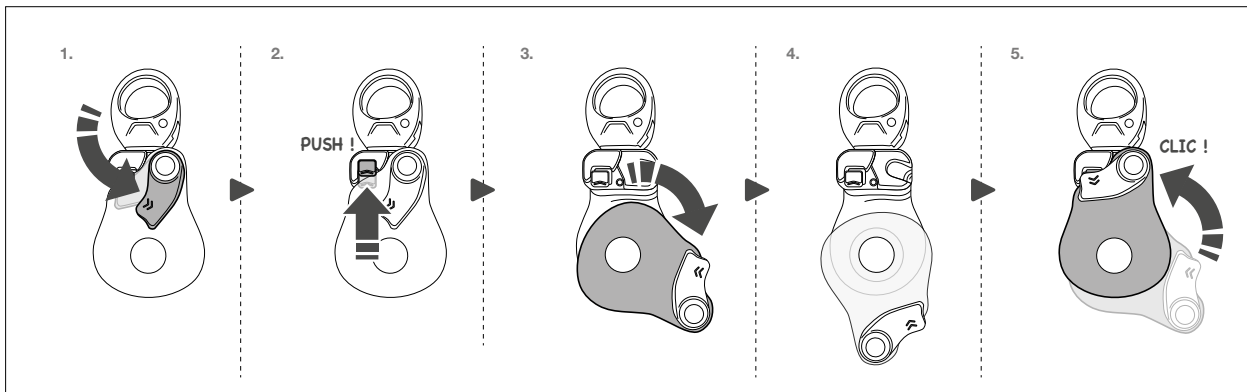

- Check the condition and function of the locking system (marks, deformation, dirt, effectiveness of the return spring(s)).

6. Function check

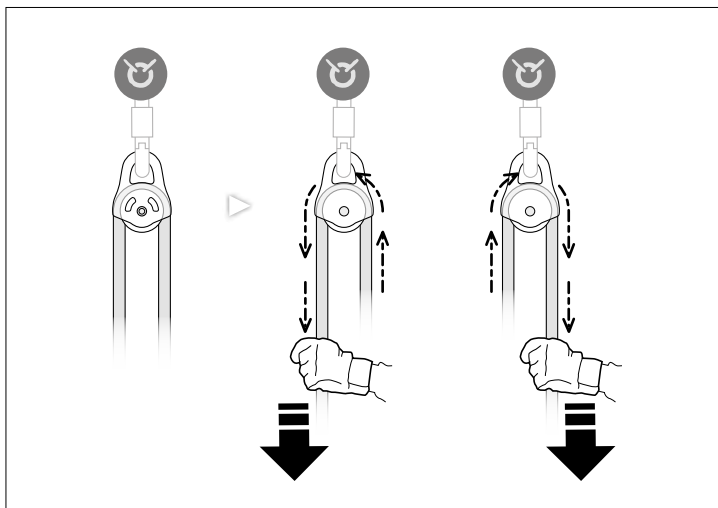

- Install your pulley on an anchor and install a compatible rope around the sheave.
- Circulate the rope in both directions.